

Experiment 13

Simulation of a Bridge Rectifier Using SPICE

Introduction

The purpose of this experiment is to gain practical experience with the mechanics of a SPICE transient simulation, and to compare the results of the simulation with a hand-worked approximate analysis. This experiment also demonstrates a widely-used power supply circuit.

Pre-Lab

Use suitable approximations to analyze the circuit of Fig. 1(a): assume T1 to be an ideal transformer and the diodes to be ideal. Sketch the expected dc output voltage waveform. Estimate the ripple amplitude. Note that the ac voltages are given as *rms* values.

Equipment Needed

- Current version of PSpice

Procedure

Turn on the PC and open the current version of PSpice. All simulations will be done using a transient analysis (.TRAN). Be sure to check the box “Skip initial bias point calculation” in the simulation setup. Set the transient simulation to run for 40 ms. You might save time by simulating both circuits in Fig. 1 simultaneously, and plotting their results together on the same graph. You will have to give each component a unique name, however.

1. Simulate the circuits of Fig. 1 using a 1N4002 diode model (any diode from the series 1N4001-4007 is OK) from the component model library. T1 can be replaced with the transient ac voltage source “VSIN.” Make the appropriate model entries for the parameters “Offset, Amplitude and Frequency.”
2. Use probe to plot the dc output voltage V_{dc} and the ac source current I_{ac} vs. time.
3. Use probe to measure the peak-to-peak output voltage. Hint: Use the cursors to measure the maximum and minimum voltage levels, and to indicate the difference between these two points.
4. Use probe to measure the time-averaged dc output voltage. Hint: In the add waveform dialog box, you can type the expression “Avg(V(x)), where V(x) is a correct expression for your output voltage. What happens?

Experiment 13 Simulation of a Bridge Rectifier Using SPICE

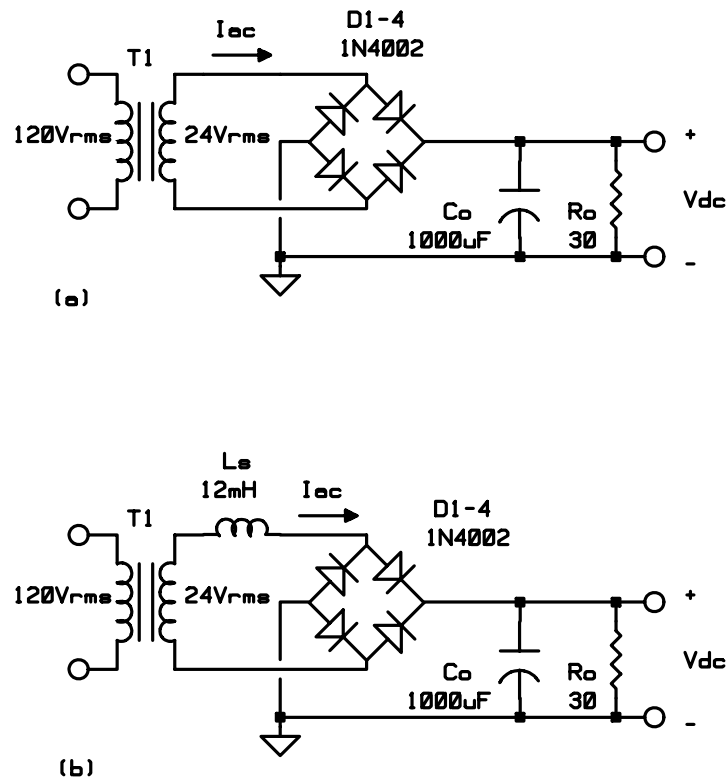

Fig. 1 Bridge rectifiers without (a) and with (b) source inductance. T1 is ideal.

Report

No formal report is required for this experiment. Simply summarize the results you have obtained in a homework format. The required results are plots of V_{dc} and I_{ac} vs. time for both Figs. 1(a) and 1(b) as produced by probe. Include the results of a hand-worked solution for Fig. 1(a). Comment on the following:

1. Is there good agreement between your simulation results and your hand-worked results for Fig. 1(a)? How well did the peak-to-peak and average output voltages agree?
2. Actual rectifier transformers have substantial leakage inductance. Comment on the effect of L_s on the circuit performance, as shown by the simulation results.
3. Make a comparison between the average current in the $30\text{-}\Omega$ load resistor and the peak current value observed in the ac source.