

Experiment 9

Analog/Digital Conversion

Introduction

Most digital signal processing systems are interfaced to the analog world through analog-to-digital converters (A/D) and digital-to-analog converters (D/A). The purpose of this experiment is to observe how the conversion process modifies the signal. A circuit board having separate sample-and-hold (S/H), A/D and D/A sections is provided for this experiment. It allows easy access to the signals at each stage of these conversion processes.

Equipment Needed

- Digital Scope with event averaging capability
- Function generator
- Analog/digital conversion circuit board

Pre Lab

Read the appropriate section(s) of your electronics text dealing with A/D and D/A conversion, as well as S/H circuits.

Procedure

1. Connect the analog/digital conversion circuit board as shown in Fig. 1. Be sure to observe correct polarity in connecting the +/- 15-V power supplies. The function generator and oscilloscope ground leads should be connected to either "analog ground." The power supply common lead is connected to "digital ground." Set the FG for a dc output¹ voltage of 0 V. Connect the scope channel 1 to the analog input (to the S/H), and channel 2 to the analog output (from the D/A converter).
2. Vary the dc voltage at the analog input slowly from 0 V to 5 V. The eight LEDs indicate the digital value of the converted analog input voltage. The 8-bit byte should vary from 00_h to FF_h. Determine what happens when the analog input voltage goes below zero, or above 5 V.
3. Using an increment of 1 mV in the analog voltage, carefully determine the voltage change (to the nearest 1 mV) required to produce a 1-bit change in the digital output. Use the dc voltmeter to accurately measure the input voltage. This is the "quantization step size" of the A/D converter.

¹ To obtain dc output from the HP 33120A, press and hold the buttons for *two* waveforms, such as sine and triangle, simultaneously for several seconds. Remember that the actual output voltage amplitude will not agree with the programmed value unless the output termination is set to "High Z."

Analog/Digital Conversion

4. Use a dc voltmeter connected between "analog ground" and " V_{REF} " to measure the internal reference voltage of the A/D and D/A converters. The result should be 5 V, plus or minus 5%. Divide V_{REF} by $(2^8 - 1)$ and compare with the quantization step size measured in the previous step. These two results should be equal.
5. Set the FG for a 100-mVpp 50-Hz triangle wave with a 100-mV dc offset. Connect channel 1 of the scope to show this analog input waveform, and connect channel 2 to show the output voltage of the sample-and-hold stage, labeled "S/H OUT." Trigger from channel 1. You will need to use event averaging to obtain a low-noise display at 50 mV/div. Record this display which documents the relationship between the low-frequency input signal and an analog sampled version of it.
6. Keep the same setup as the previous step, except move channel 2 to the "analog output." This output shows the result of digitizing the sampled signal, and then converting it back to analog form. Record this display which documents the relationship between the low-frequency input signal and a sampled and quantized version of it.

Report

1. Discuss the meaning of "quantization step size." Give its numerical value for this A/D converter as measured in steps 3 and 4.
2. Determine the quantization step size from the waveform recorded in step 6. Include this waveform in your report and label it to show how the quantization step size was determined from it. Note that this is the quantization step size for the D/A converter, not the A/D converter.
3. Compute the signal-to-noise ratio (SNR) of the signal leaving the D/A converter in this experiment. Assume that the signal is (a) a sine wave, adjusted to have a peak-to-peak voltage exactly equal to the full-scale voltage of the D/A converter, and (b) a sine wave having a peak-to-peak voltage of 100 mV. For comparison, the SNR of a vinyl record in new condition playing a loud passage of music is about 60 dB, dropping to 40 dB as it wears out, and a CD player can achieve better than 90 dB SNR.
4. Describe in a qualitative manner what the S/H section is doing. (You may need to do some library research to answer this.)

Reference - Signal-to-Noise Ratio

As you have observed in this experiment, the output signal from the D/A converter is actually a "stair-step" approximation to the original continuous input signal. The difference between the output and input signals can be considered to be noise. Approximate calculations (which assume that the signal is not correlated with the conversion clock) give the rms noise voltage as follows:

Analog/Digital Conversion

$$V_{n,rms} = \frac{V_{REF}}{\sqrt{12} \cdot 2^b} \quad (1)$$

where b is the number of bits used (8 in this case) and V_{REF} is the D/A reference voltage. The rms value of the processed signal should be computed based only on its ac content. SNR is defined as follows:

$$SNR = \left[\frac{V_{sig,rms}}{V_{n,rms}} \right]^2 \quad (2)$$

SNR is most commonly stated in decibel notation as:

$$SNR_{dB} = 10 \log_{10} \left[\frac{V_{sig,rms}}{V_{n,rms}} \right]^2 = 20 \log_{10} \left[\frac{V_{sig,rms}}{V_{REF}} \right] + 10.8 + 6b \quad (3)$$

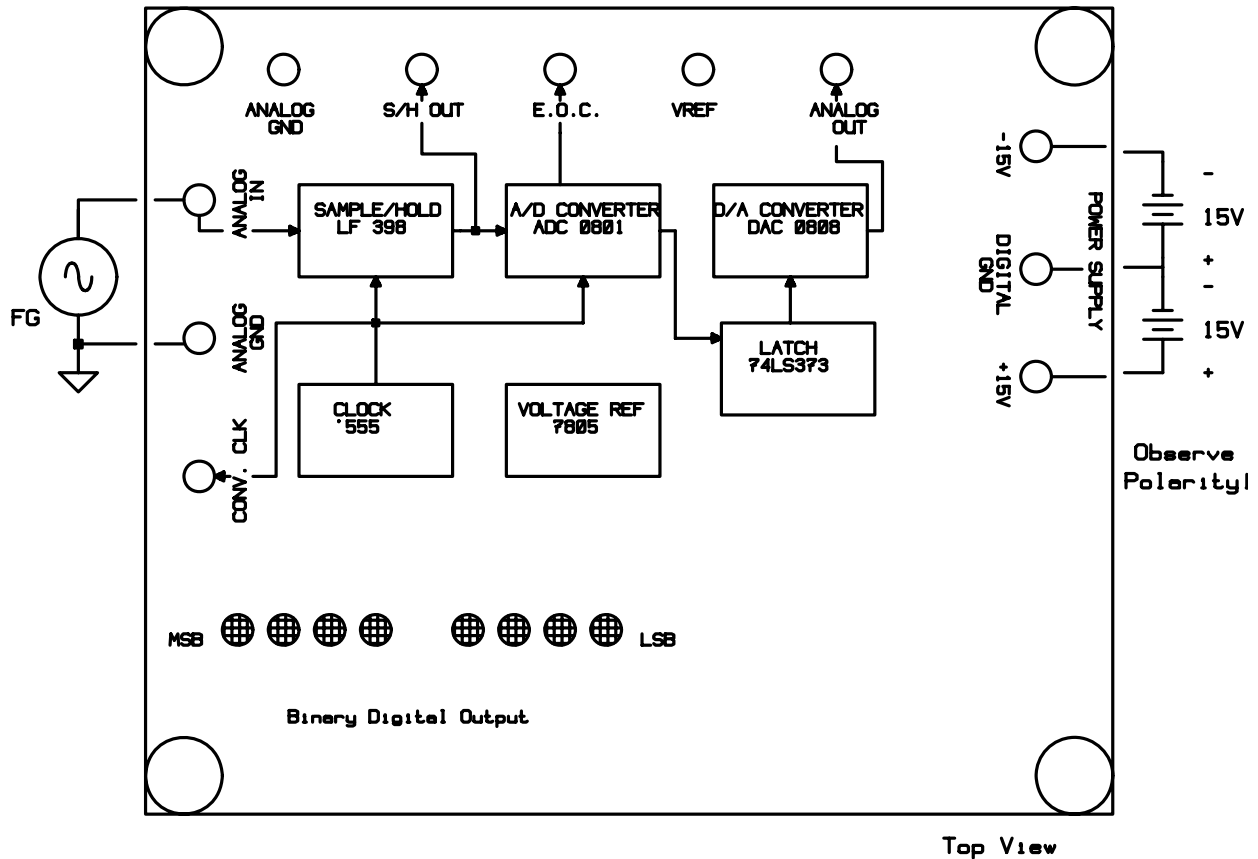

Fig. 1 Top view of analog/digital conversion experiment circuit board. Observe polarity when connecting the +/- 15-V power supplies.

A/D AND D/A CONVERSION CIRCUIT

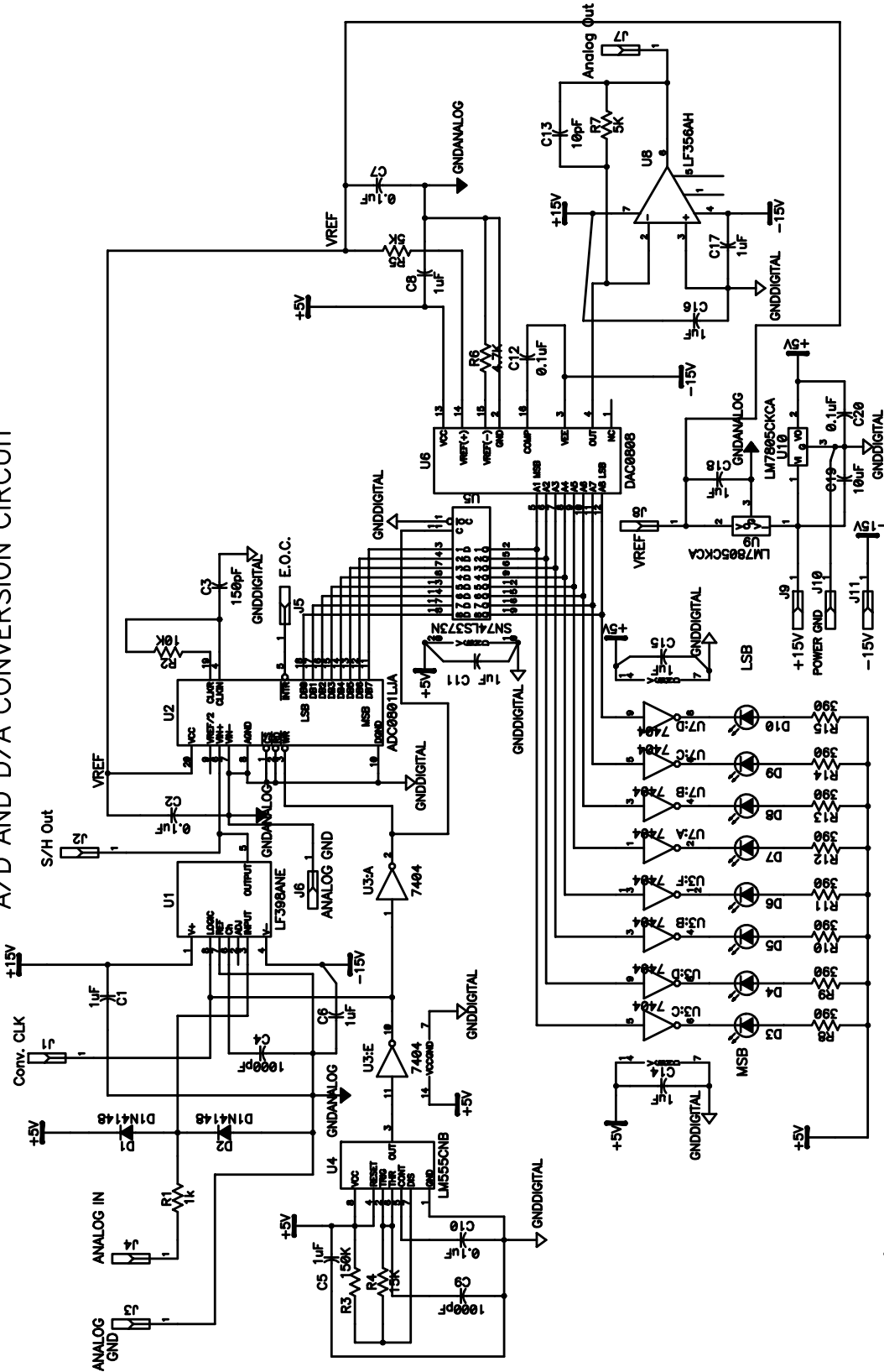

Fig. 2 Schematic diagram of analog/digital conversion experiment circuit board.